

## Linear Guide (IKO) Replacement Maker 12, Edge 12, 24 & 36, Pro 24 & 36

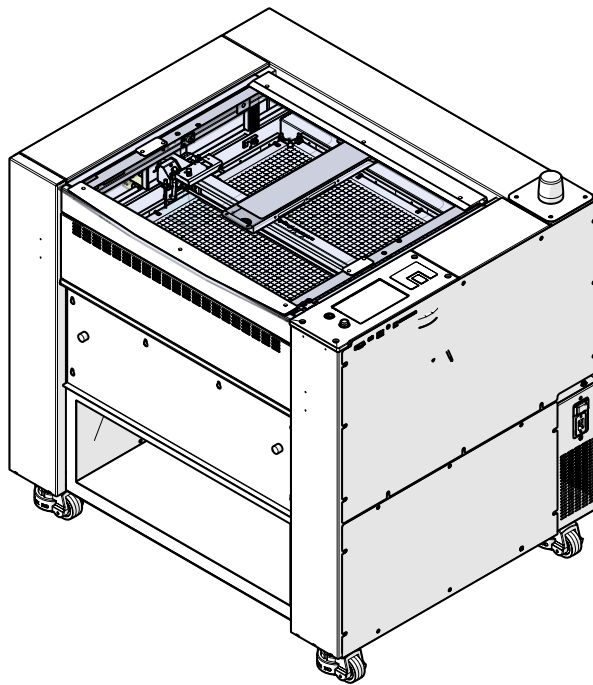

### Parts Required

- X-Axis Assembly

### Tools/ Materials Required

- 3/32" Allen wrench
- 5/32" Allen wrench
- 7/64" Allen wrench
- Phillips head screwdriver

# Linear Guide Replacement

## Linear Guide Removal

1. Turn off the engraver.
2. Disconnect the engraver from power source.
3. Remove the left and right panels of the engraver:

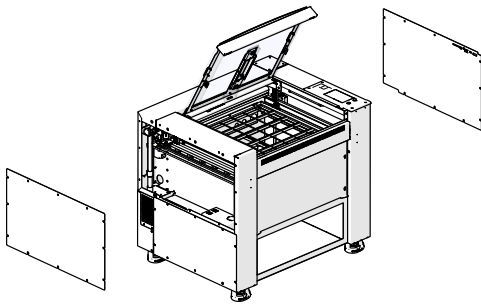

4. Loosen and remove the lens tube assembly from the x-axis assembly:

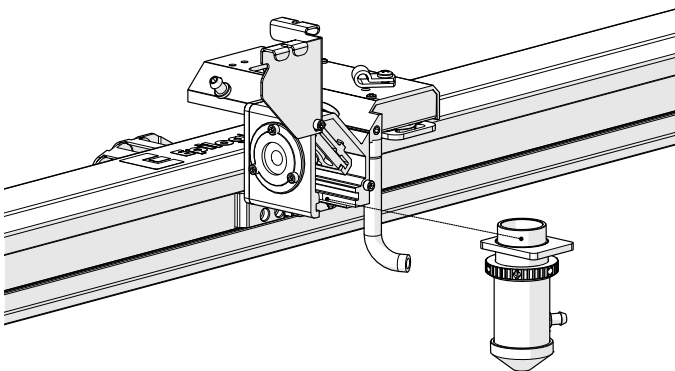

5. Remove the x-axis drive board cover:

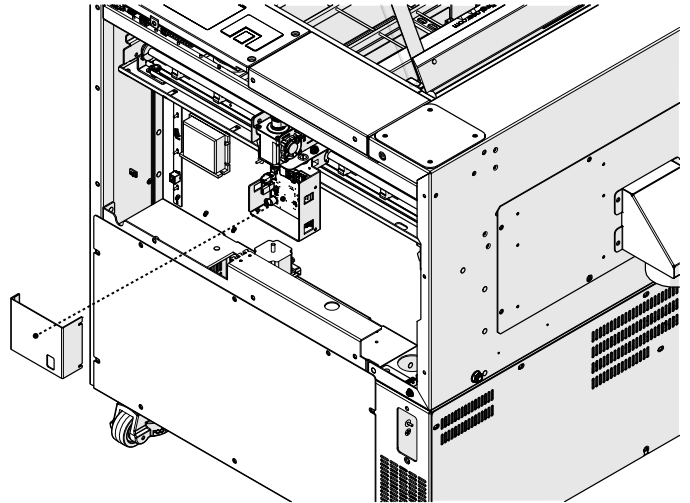

6. Disconnect the air assist tubing from the right side of the x-axis assembly:

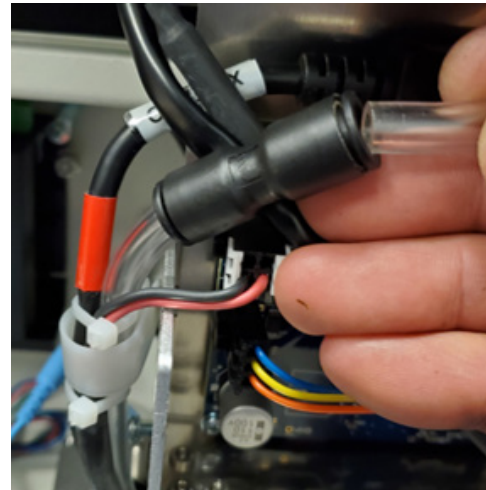

---

The AA tubing is held by a tubing coupler. To remove the tubing, press the tubing into the fixture. Then, while holding the retaining ring tight to the fixture, pull the AA tubing away from it.

---

For Fusion Maker engravers, proceed to step 10.

## 17000 - Linear Guide Replacement

7. Remove the six (6) electrical connections on the drive board:

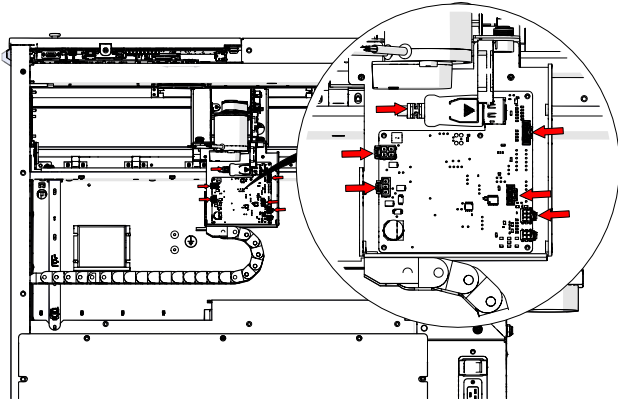

8. Loosen and remove the three (3) Phillips screws that secure the x-axis drive board mounting bracket to the x-axis assembly:

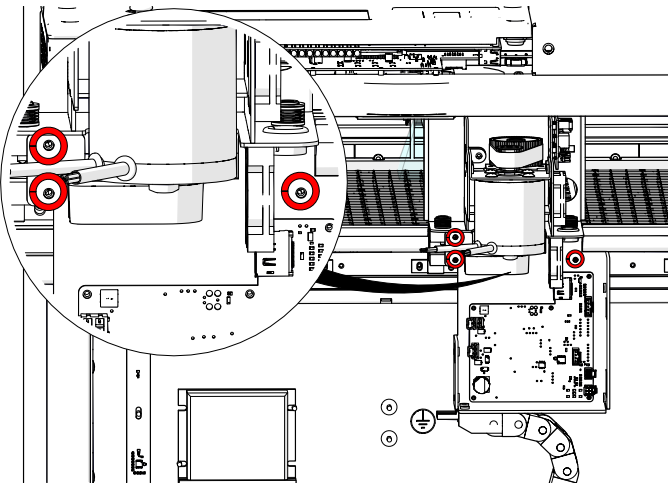

9. Remove the x-axis drive board and housing:

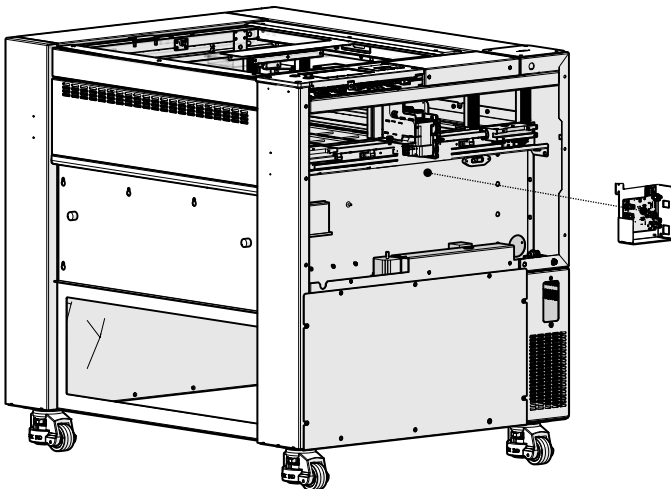

10. Disconnect the belows on the left and right side of the engraver.

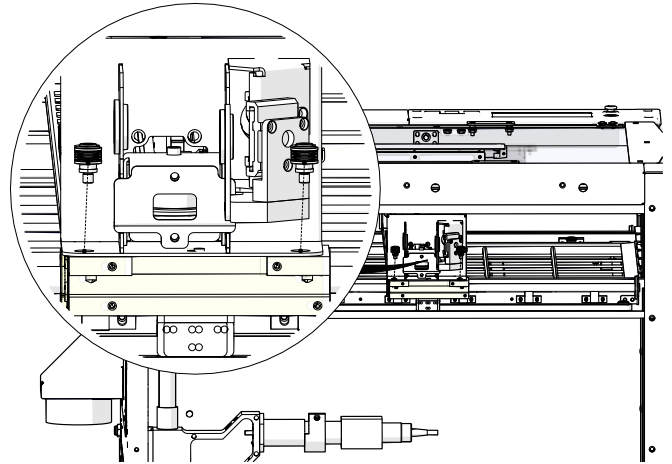

11. Remove the four (4) fasteners that secure the x-axis assembly to the y-axis bearings. There are two (2) on the right side and two (2) on the left side:

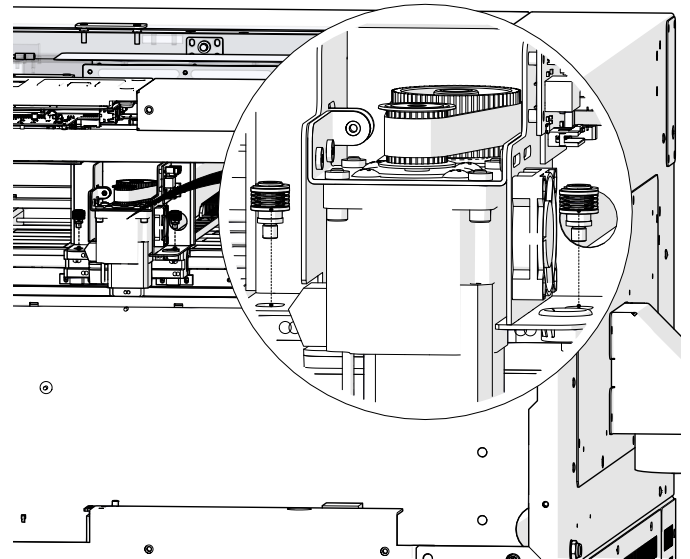

## 17000 - Linear Guide Replacement

12. Gently lift on the x-axis assembly to free it from the locator pins on the y-axis bearing blocks:

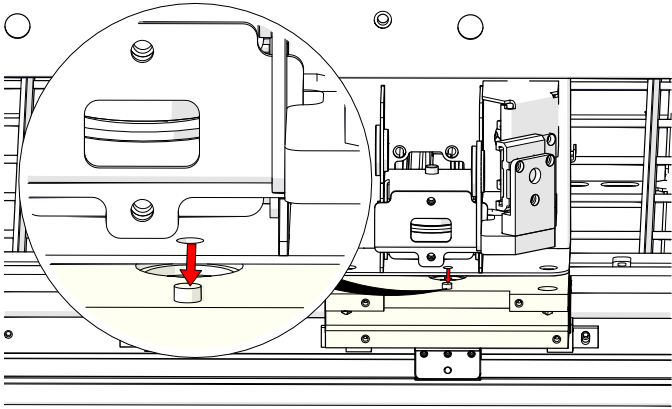

13. Slide the x-axis assembly out of the cabinet through the right side of the engraver:

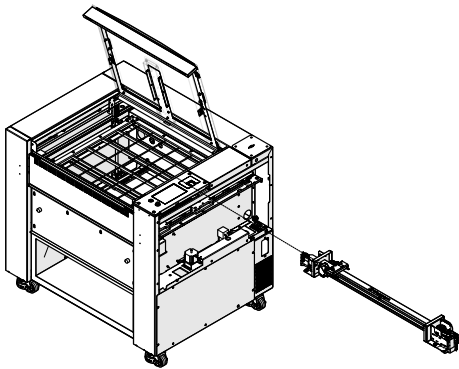

14. Loosen and remove the 3/32" Allen screw that secures the autofocus switch to the carriage assembly:

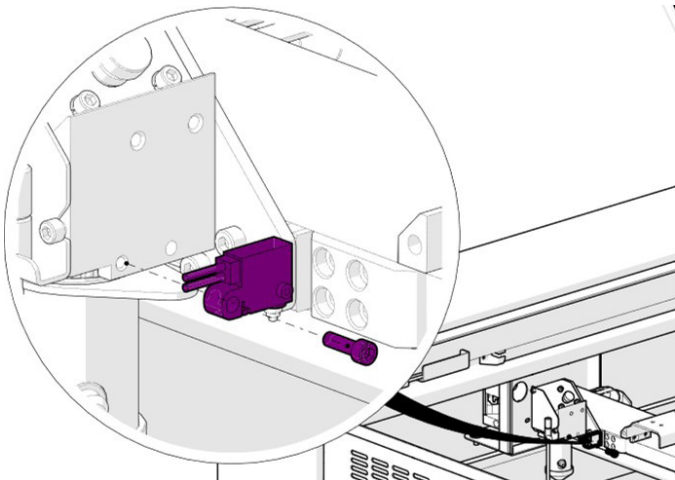

15. Remove the autofocus switch.

16. Loosen and remove the four (4) 3/32" Allen screws that secure the carriage assembly to the carriage assembly mounting plate:

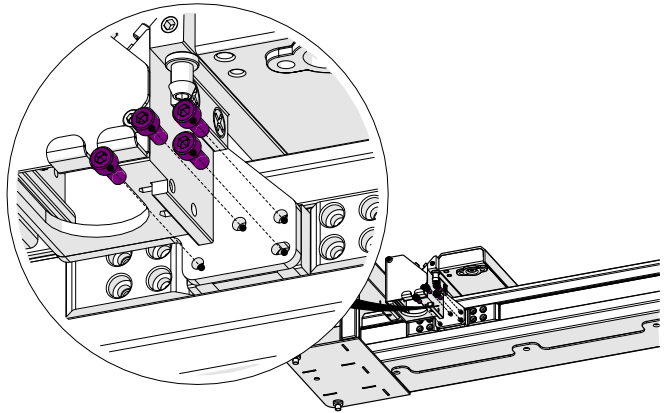

17. Remove the carriage assembly:

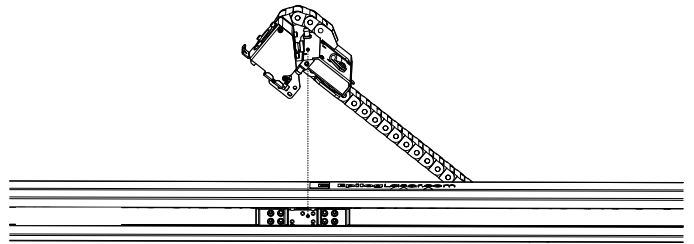

# 17000 - Linear Guide Replacement

18. Loosen, but do not remove the eight (8) 7/64" Allen screws on the x-axis idler assembly:

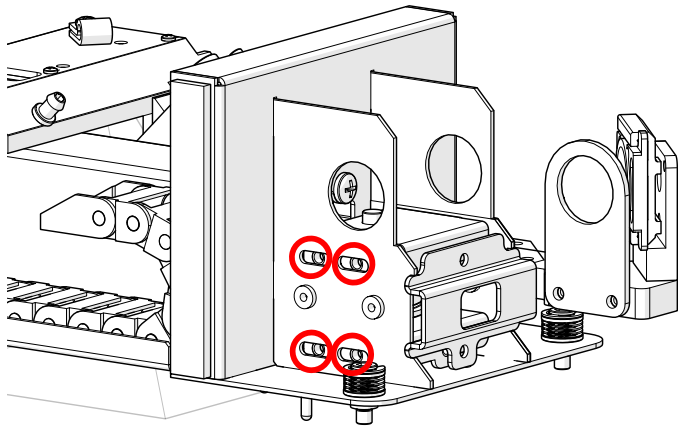
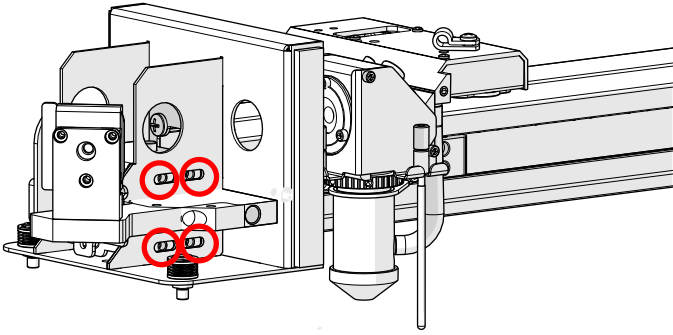

19. Loosen and remove the two (2) 7/64" tensioner screws on the idler assembly body:

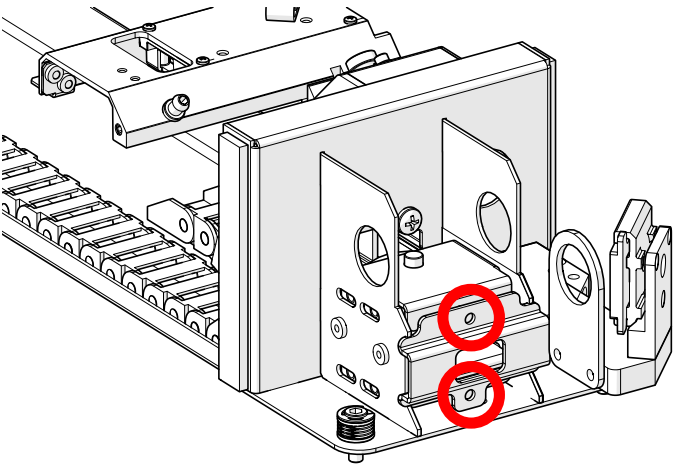

20. Remove the idler assembly front cover:

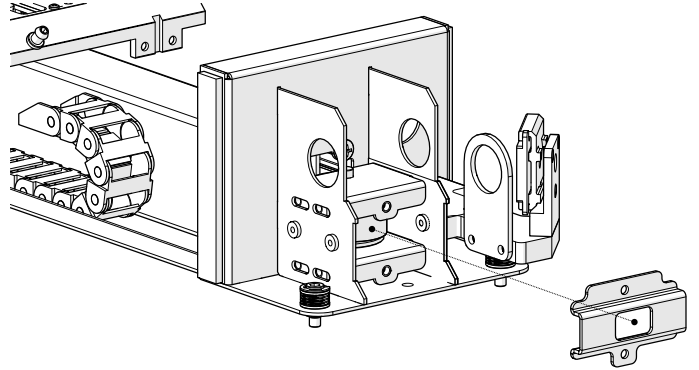

21. Remove the top four (4) 7/64" Allen screws on the x-axis idler assembly:

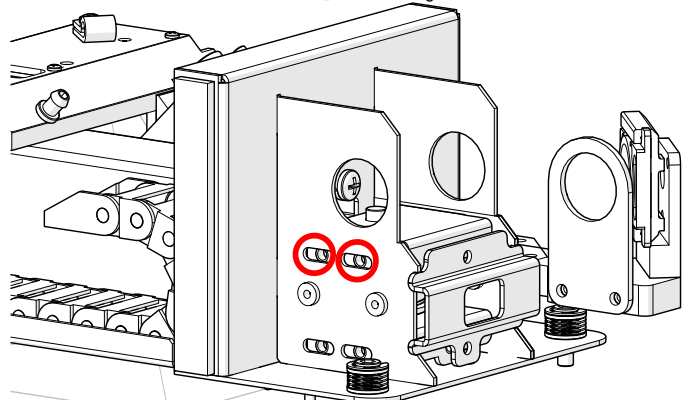
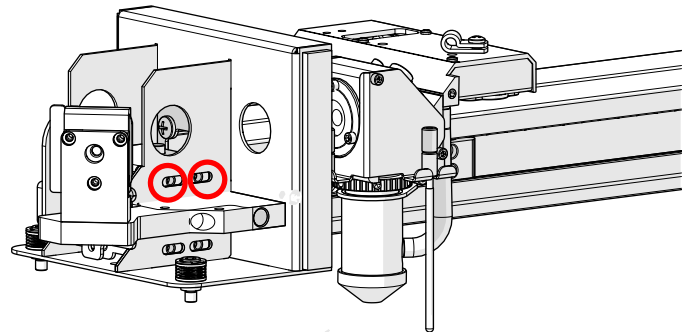

## 17000 - Linear Guide Replacement

22. Remove the upper tensioner bracket and the upper Delrin washer on top of the idler pulley:

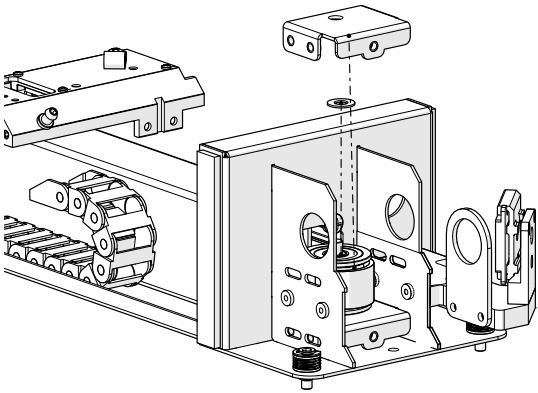

23. Remove the idler pulley, ensuring that the Delrin washer beneath it stays in place:

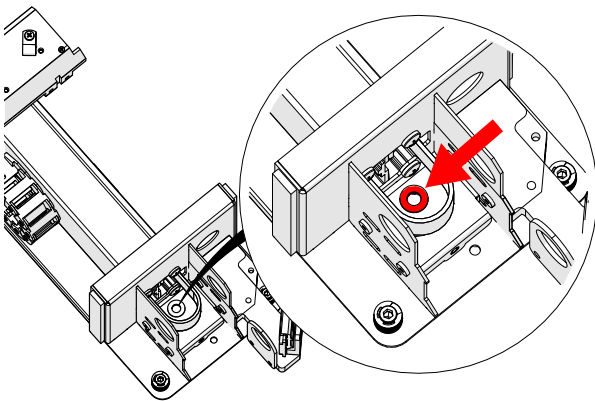
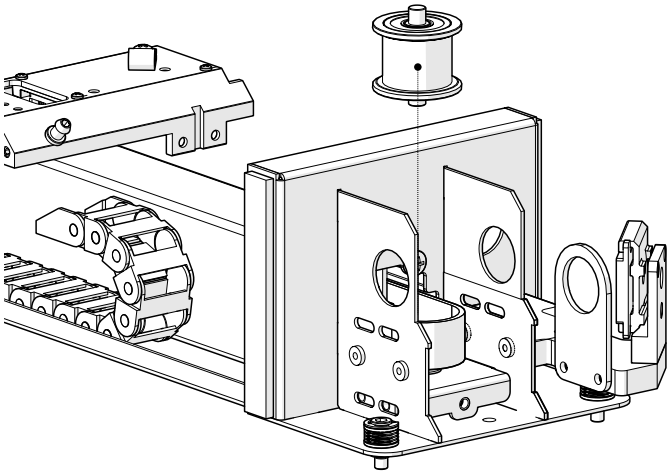

24. Loosen and remove the four (4) 3/32" screws that secure the x-axis belt clamps to the linear guide slider block:

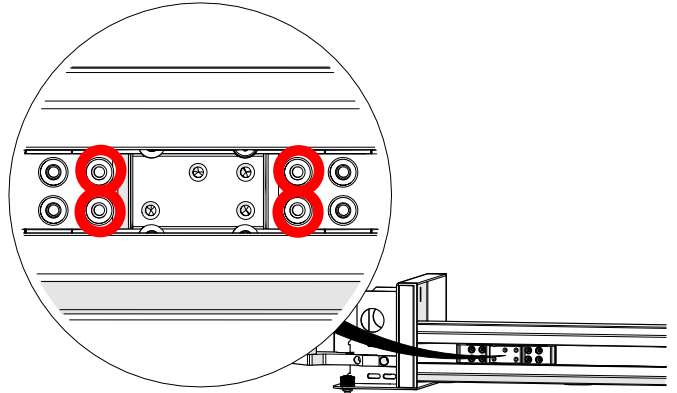

25. Remove the left and right x-axis belt clamps from inside the x-axis assembly:



26. Loosen and remove the four (4) Phillips screws that secure the x-axis assembly end plate to the left side of the x-axis assembly and remove the end plate:

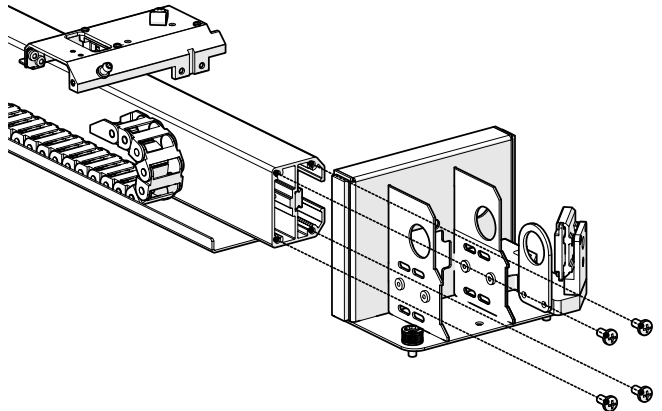

## 17000 - Linear Guide Replacement

27. Pull the x-axis belt away from the interior of the x-axis assembly to uncover the IKO rail:

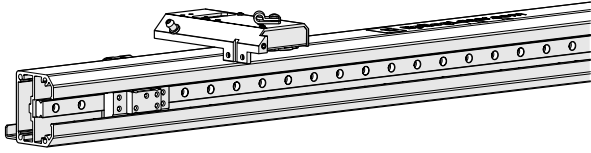

28. Loosen and remove the 3/32" Allen screws that secure the IKO rail bump stops on the left and right side of the IKO rail, taking note of their position for re-installation:

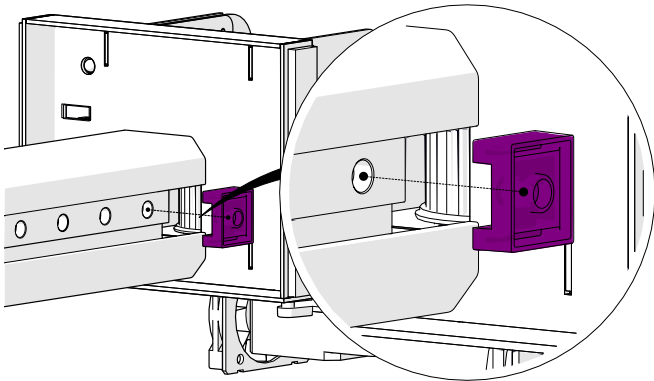
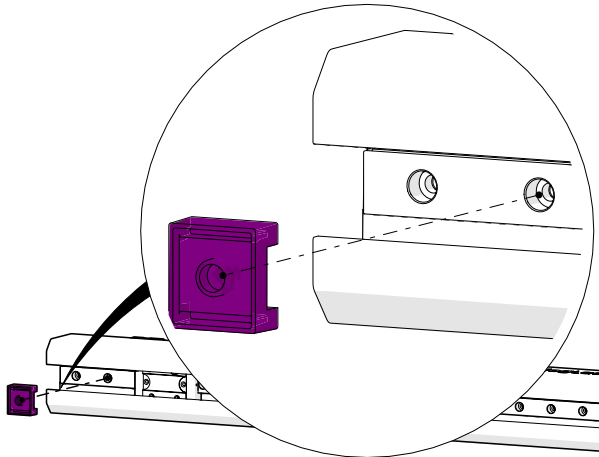

29. Loosen and remove the remaining 3/32" Allen screws on the IKO rail:

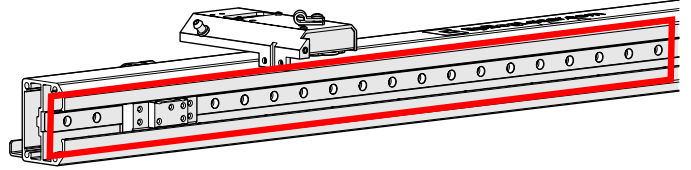

---

There are unused screw holes in the IKO rail as the mounting screws are installed in every other opening.

---

30. After removing all of the IKO mounting screws, slide the IKO rail out through the left side of the x-axis assembly:

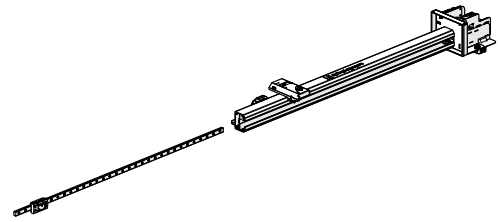

## Linear Guide Installation

1. Slide the IKO rail in through the left side of the x-axis assembly:

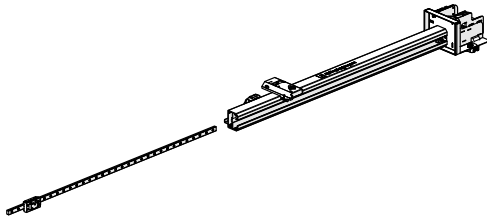

2. Place the IKO rail bump stops into position at the left and right side of the IKO rail, install and tighten the 3/32" Allen screws that secure them:

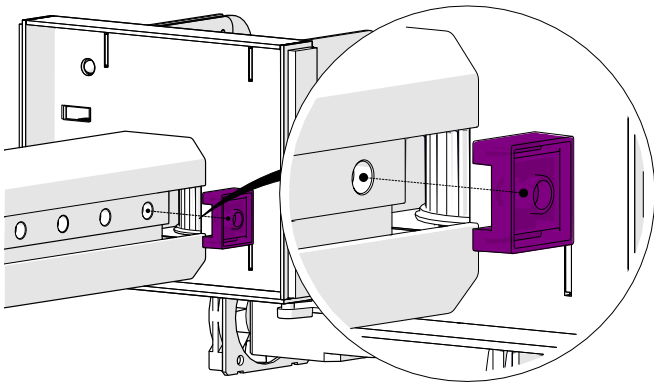
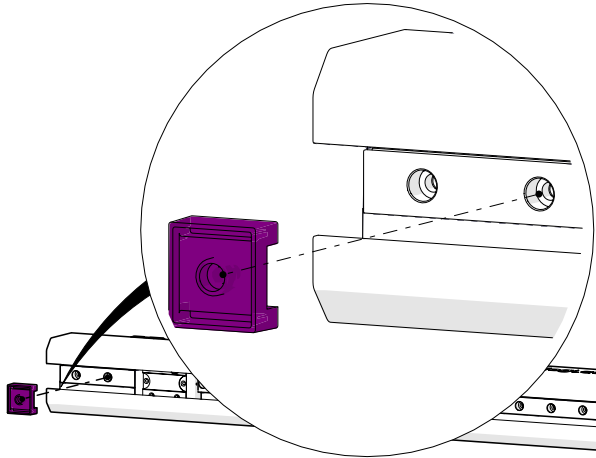

3. Install and tighten the remaining 3/32" Allen screws on the IKO rail in every other screw opening:

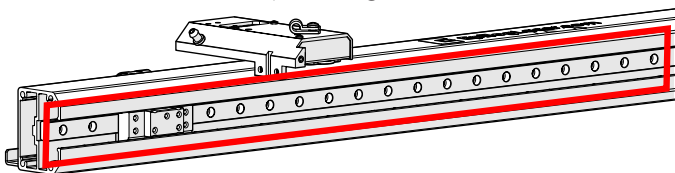

4. Place the end plate into position at the left side of the x-axis assembly. Install and tighten the four (4) Phillips screws that secure it:

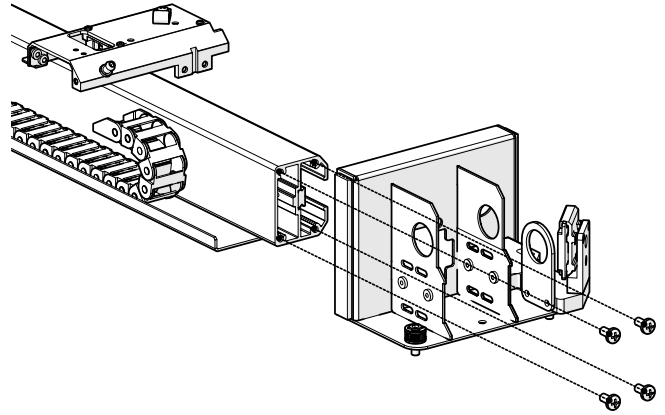

5. Place the x-axis belt back into the interior of the x-axis assembly. Place the x-axis belt clamps into position and install and tighten the four (4) 3/32" screws that secure them to the linear guide slider block:

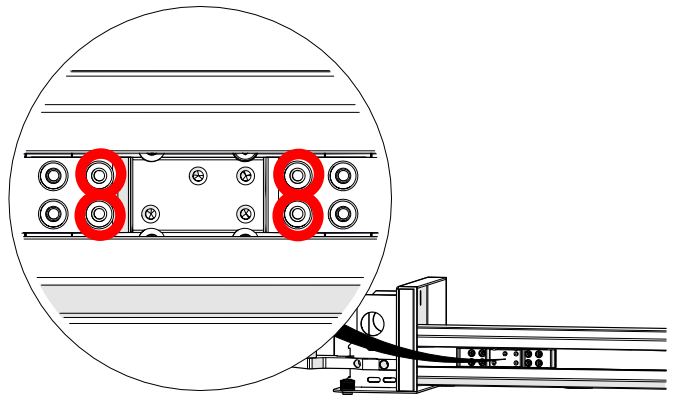

## 17000 - Linear Guide Replacement

6. Ensure that the lower Delrin washer is in the correct position to allow the idler shaft to enter it and the opening on the idler body:

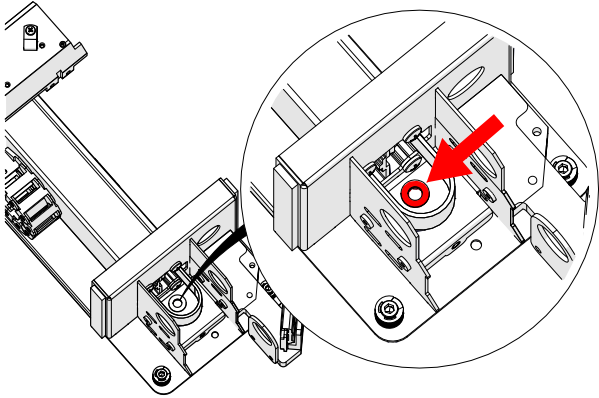

7. Install the idler pulley:

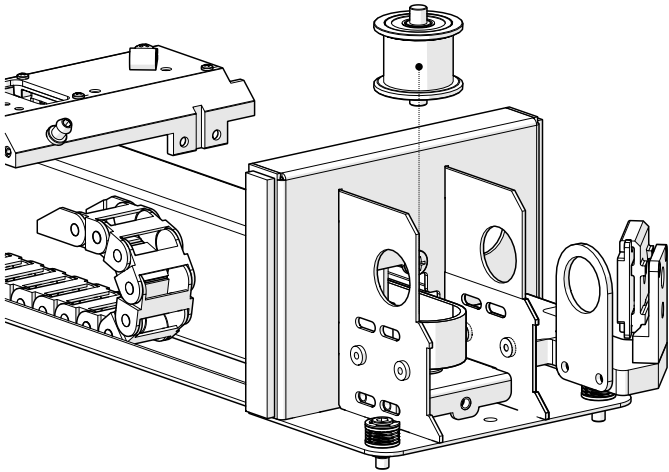

8. Install the upper Delrin washer and upper tensioner bracket:

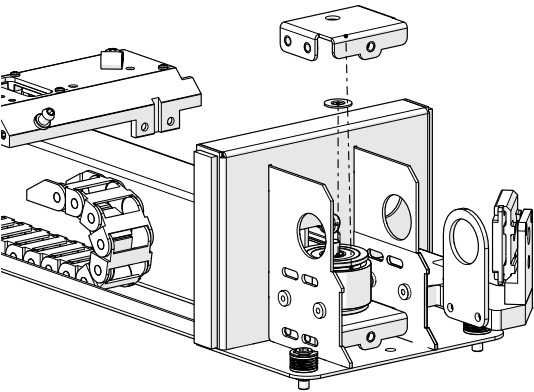

9. Install, but do not fully tighten the top four (4) 7/64" Allen screws on the x-axis idler assembly:

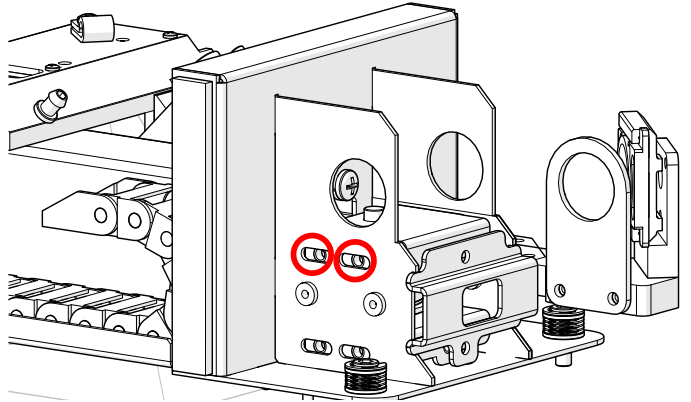
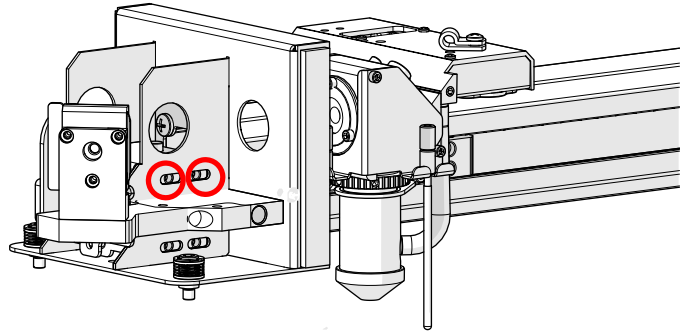

10. Install the idler assembly front cover:

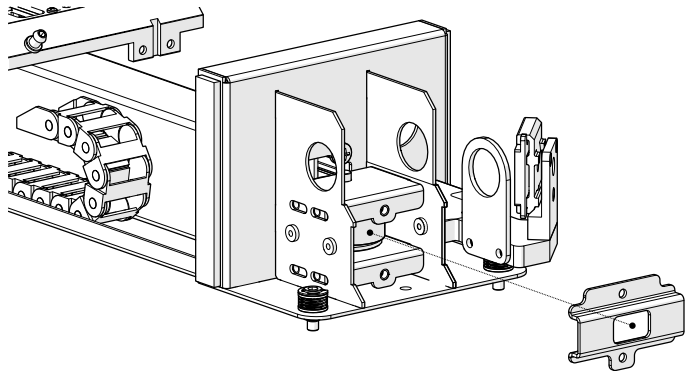

## 17000 - Linear Guide Replacement

11. Install and tighten the two (2) 7/64" Allen screws on the x-axis belt tensioner bracket to remove excess slack from the x-axis belt:

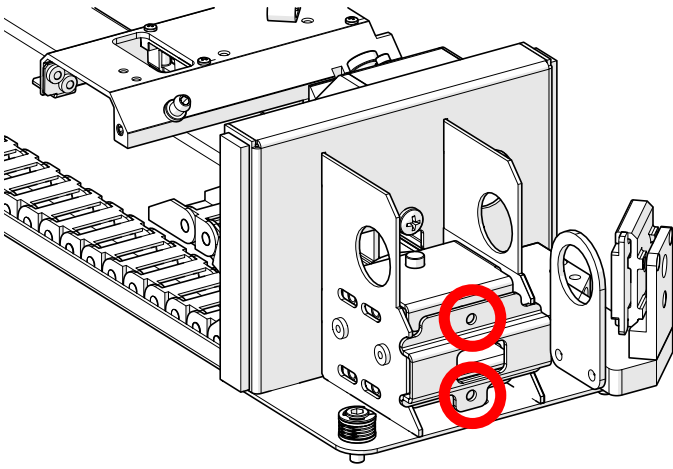

12. Place the carriage assembly into position. Install and tighten the four (4) 3/32" Allen screws that secure it to the carriage assembly mounting plate:

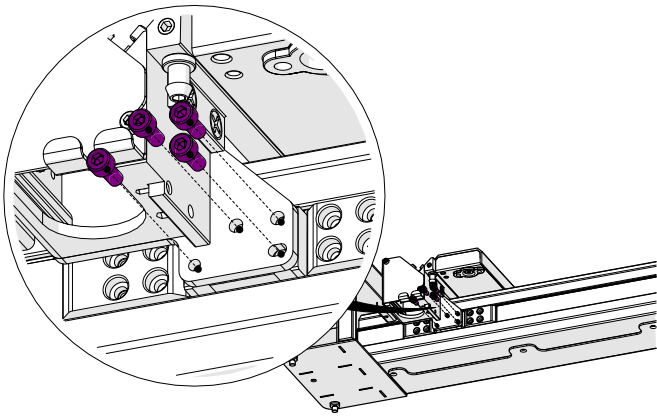

13. Place the autofocus switch into position. Install and tighten the 3/32" Allen screw that secures it to the carriage assembly:

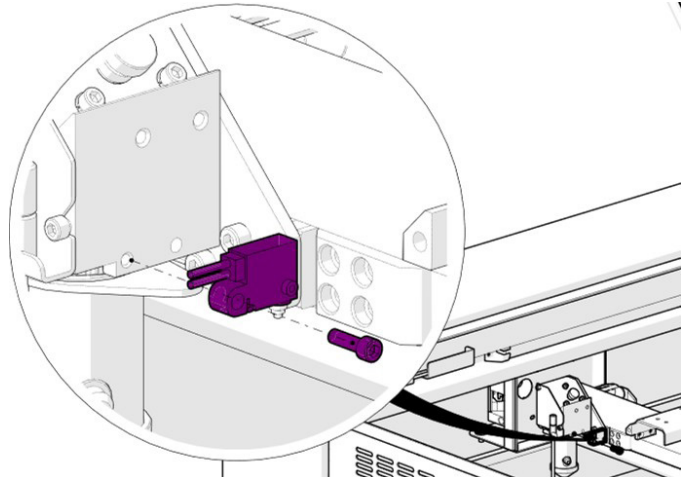

14. Slide the x-axis assembly into the cabinet through the right side of the engraver:

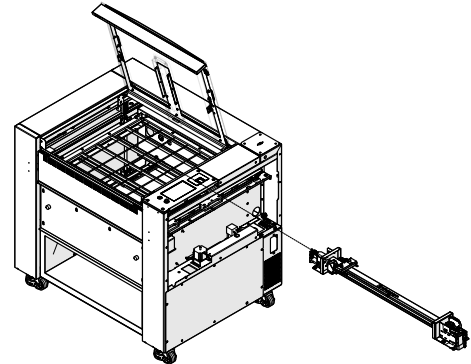

15. Place the x-axis assembly on the y-axis bearing blocks ensuring that it sits on the locator pins:

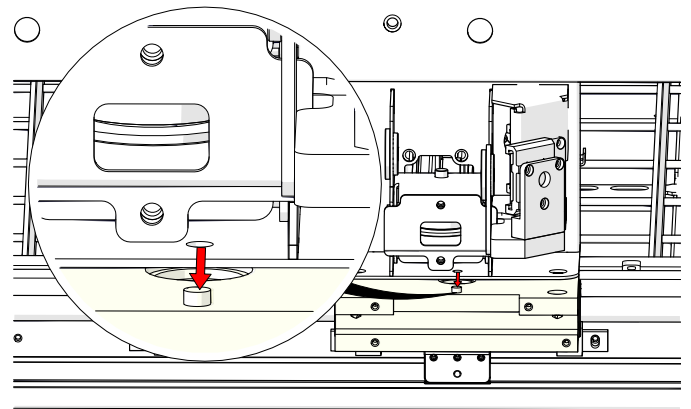

For Fusion Maker engravers, proceed to step (enter #)

## 17000 - Linear Guide Replacement

16. Install and tighten the four (4) fasteners that secure the x-axis assembly to the y-axis bearings. There are two (2) on the right side and two (2) on the left side:

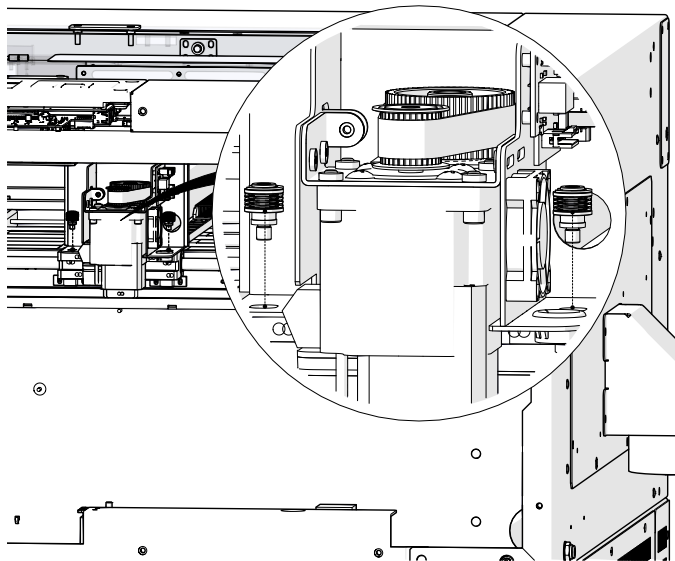
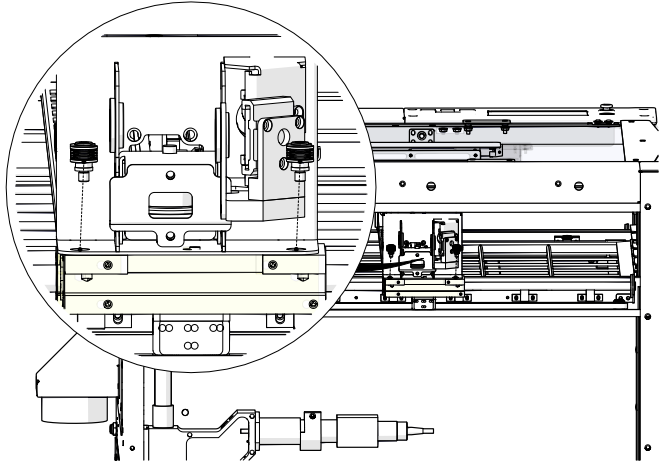

17. Place the x-axis drive board and housing into position:

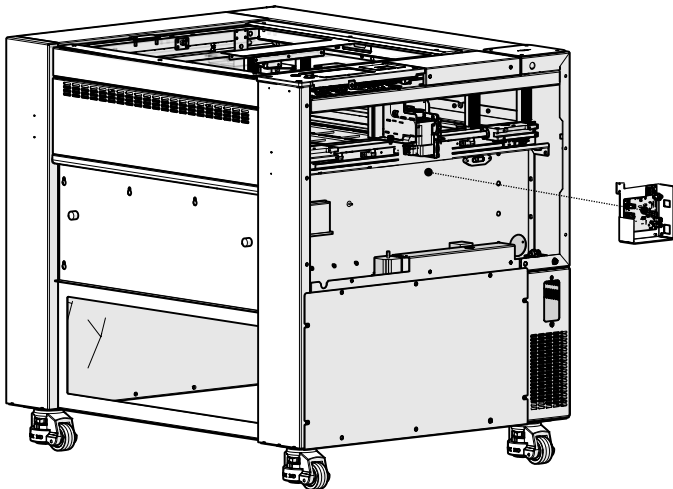

18. Install and tighten the three (3) Phillips screws that secure the x-axis drive board mounting bracket to the x-axis assembly:

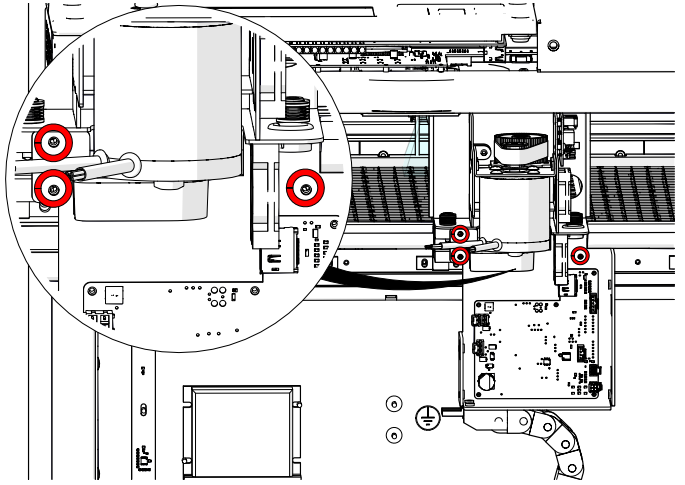

19. Connect the six (6) electrical harnesses on the drive board:

