

Focus Calibrations

Fusion Maker - Fusion Edge - Fusion Pro 24, 32, 36 & 48

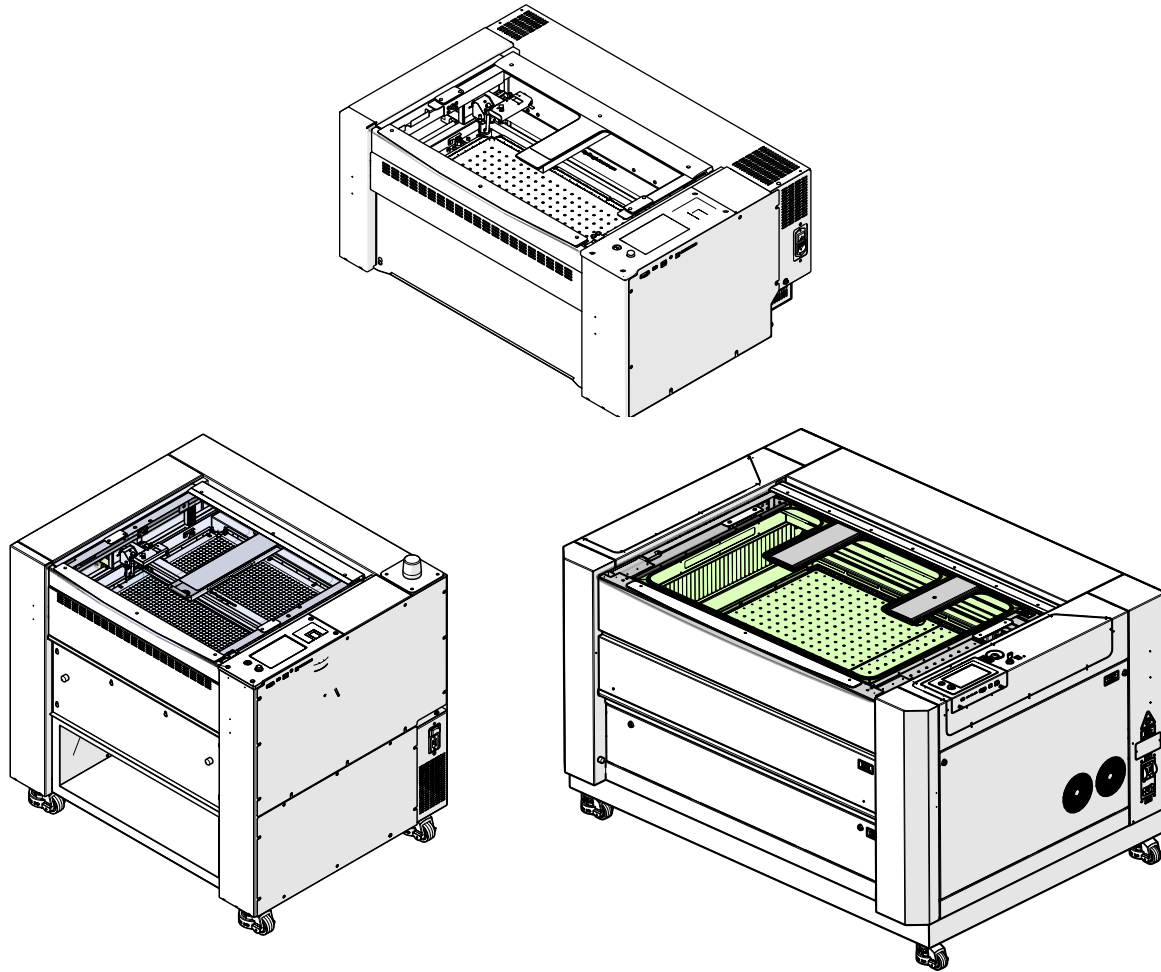

Contents

- CO2- Only Engravers 2
- Fiber- Only Engravers 6
- Dual Source Engravers 10

Tools/ Materials Required

- Anodized Aluminum

Focus Calibrations for CO2- Only Engravers

Focus calibrations must be completed periodically to ensure that the engraver is operating at the correct focal height. Complete this procedure if any of the following behaviors are observed:

- Autofocus is not working.
- Autofocus is moving the table too high or low.
- Laser power appears weak.
- Table movement appears to not coincide with user focus input or crashes.
- Issues with camera calibration.

Additionally, certain component replacements require that the focus calibration procedure to be completed. These components include:

- Z-Axis PCB
- Laser tube
- Control module

Focus calibration must be completed in the order outlined in this procedure.

Table Calibration

The table calibration is a crucial step in the laser focus calibration. During this procedure the table will move from the top to the bottom of the z-axis locating the magnetic sensors along the z-axis PCB. This step must be completed for a successful and accurate focus calibration.

1. Before completing the table calibration install the raster table if your engraver is equipped with one.

2. Use the Jog feature to position the lens carriage in a position which will prevent the autofocus plunger and lens cone from coming into contact with the left and or top ruler guides.
3. On the display, press the gear icon to enter the Settings menu:



4. Once in the Settings menu, press the Focus button to enter the Focus Commands/Calibrations menu:

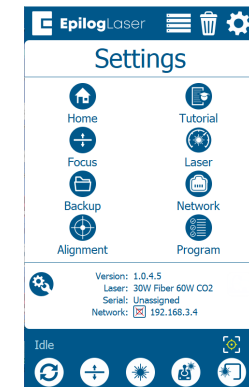

5. Press the Table button:



Focus Calibrations

6. Press the Start button to start the table calibration:

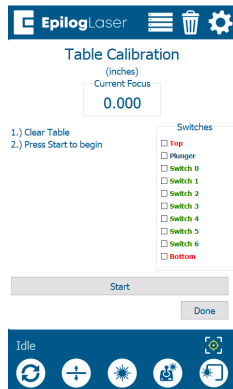

7. Allow the engraver to complete the calibration. Once complete, a success message should appear.
8. Move to the CO2 Focus Procedure.

CO2 Focus Calibration

The CO2 focus calibration establishes the focal height of the laser. You will run a small job while adjusting the table height to find the correct focal height.

A small piece of anodized aluminum (at least 3" x 3" or 75mm x 75mm) is required to complete this procedure.

1. Open your preferred illustrating program and create a black, raster box measuring ~2" x 2" or 50mm x 50mm.
2. Send the job to the Software Suite.
3. Ensure that the process shows as an engraving job and set the both power and speed at 5-10%.

4. Send the job to the engraver.

5. Once the job is running press the Focus button and slightly raise and lower the table with the joystick while observing the spark coming from the laser hitting the anodized aluminum:

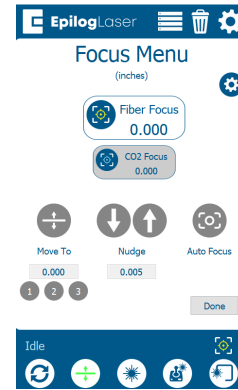

6. While raising and lowering the table, find the height where the spark appears the brightest. If it is difficult to determine, turn off any overhead lights in the room.
7. Once the appropriate table height is found, use the touchpad to lower the power to 3-5%:

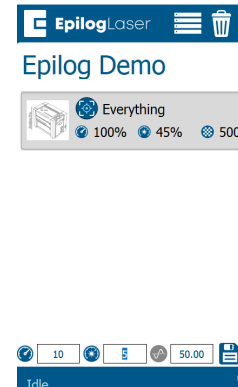

Focus Calibrations

- Continue to raise and lower the table height with the lower power setting to find the height where the spark appears the brightest.

Using the lower power setting allows you to more finely dial in the correct focal height as the spark will fade very quickly when the material becomes out of focus.

- Once the correct focal height has been found, let go of the joystick and press the Go/Stop button to stop the job. Then press the Reset button to return the laser head back to the home position.
- Remove the anodized aluminum from the engraver.
- On the display, press the gear icon to enter the Settings menu:



- Once in the Settings menu, press the Focus button to enter the Focus Commands/Calibrations menu:

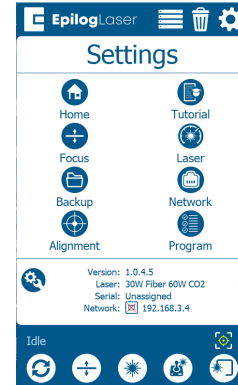

- Press the CO2 Focus button:



- Ensure that the material thickness used during the previous step is entered in the Thickness box. If using anodized aluminum provided by Epilog Laser, the default value of 0.025" corresponds to the material.

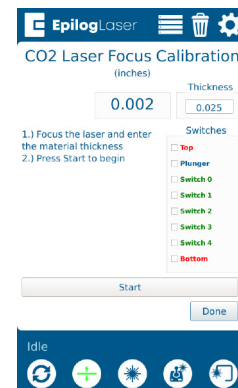

Focus Calibrations

15. Press the Start button. This calibration is very fast as the engraver simply notes and saves the current position of the table.
16. Press Done.
17. Move to the Autofocus Calibration procedure.

Autofocus Calibration

The autofocus calibration takes note of, saves, and uses the CO2 focus calibration value to ensure that the table moves to the correct focal height when running a job with the autofocus enabled. During this calibration the table will rise up, depress the autofocus plunger, and then move back to the appropriate focal height.

1. Before completing the autofocus calibration, install the raster table if your engraver is equipped with one.
2. Since the table will rise to depress the autofocus plunger, use the Jog feature to position the lens carriage in a position which will prevent the autofocus plunger and lens cone from coming into contact with the left and or top ruler guides.
3. On the display, press the gear icon to enter the Settings menu:



4. Once in the Settings menu, press the Focus button to enter the Focus Commands/Calibrations menu:

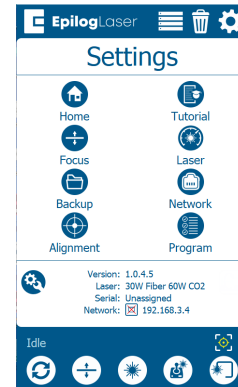

5. Press the AF Plunger button:



6. Press the Start button:



7. Allow the engraver to complete the calibration. Once complete, a success message should appear.

Focus Calibrations for Fiber- Only Engravers

Focus calibrations must be completed periodically to ensure that the engraver is operating at the correct focal height. Complete this procedure if any of the following behaviors are observed:

- Autofocus is not working.
- Autofocus is moving the table too high or low.
- Laser power appears weak.
- Table movement appears to not coincide with user focus input or crashes.
- Issues with camera calibration.

Additionally, certain component replacements require that the focus calibration procedure to be completed. These components include:

- Z-Axis PCB
- Laser tube
- Control module

Focus calibration must be completed in the order outlined in this procedure.

Table Calibration

The table calibration is a crucial step in the laser focus calibration. During this procedure the table will move from the top to the bottom of the z-axis locating the magnetic sensors along the z-axis PCB. This step must be completed for a successful and accurate focus calibration.

1. Before completing the table calibration install the raster table if your engraver is equipped with one.

2. Since the table will rise to depress the autofocus plunger, use the Jog feature to position the lens carriage in a position which will prevent the autofocus plunger and lens cone from coming into contact with the left and or top ruler guides.
3. On the display, press the gear icon to enter the Settings menu:



4. Once in the Settings menu, press the Focus button to enter the Focus Commands/Calibrations menu:



5. Press the Table button:



Focus Calibrations

6. Press the Start button to start the table calibration:

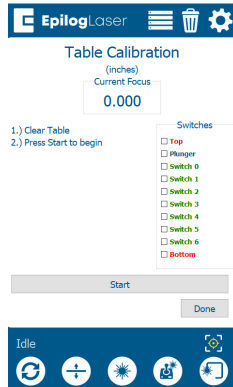

7. Allow the engraver to complete the calibration. Once complete, a success message should appear.

8. Move to the Fiber Focus Procedure.

Fiber Focus Calibration

The fiber focus calibration establishes the focal height of the laser. You will run a small job while adjusting the table height to find the correct focal height.

A small piece of anodized aluminum (at least 3" x 3" or 75mm x 75mm) is required to complete this procedure.

1. Open your preferred illustrating program and create a black, raster box measuring ~2" x 2" or 50mm x 50mm.
2. Send the job to the Software Suite.
3. Ensure that the process shows as an engraving job and set the both power and speed at 5-10%.

4. Send the job to the engraver.

5. Once the job is running press the Focus button and slightly raise and lower the table with the joystick while observing the spark coming from the laser hitting the anodized aluminum:

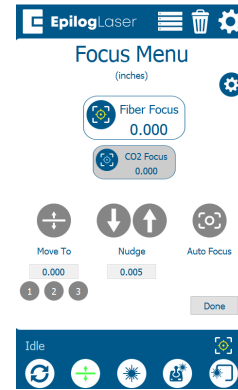

6. While raising and lowering the table, find the height where the spark appears the brightest. If it is difficult to determine, turn off any overhead lights in the room.
7. Once the appropriate table height is found, use the touchpad to lower the power to the lowest power possible while still producing a spark:

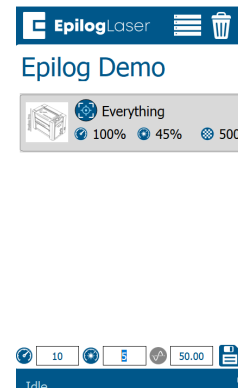

Focus Calibrations

- Continue to raise and lower the table height with the lower power setting to find the height where the spark appears the brightest.

Using the lower power setting allows you to more finely dial in the correct focal height as the spark fades very quickly when the material becomes out of focus.

- Once the correct focal height has been found let go of the joystick and press the Go/Stop button to stop the job. Then press the Reset button to return the laser head back to the home position.
- Remove the anodized aluminum from the engraver.
- On the display, press the gear icon to enter the Settings menu:

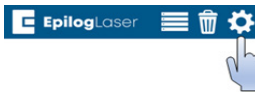

- Once in the Settings menu, press the Focus button to enter the Focus Commands/Calibrations menu:

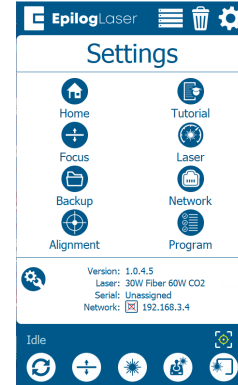

- Press the Fiber Focus button:



- Ensure that the material thickness used during the previous step is entered in the Thickness box. If using anodized aluminum provided by Epilog Laser, the default value of 0.025" corresponds to the material.

Focus Calibrations

15. Press the Start button. This calibration is very fast as the engraver simply notes and saves the current position of the table.
16. Press Done.
17. Move to the Autofocus Calibration procedure.

Autofocus Calibration

The autofocus calibration takes note of, saves, and uses the fiber focus calibration value to ensure that the table moves to the correct focal height when running a job with the autofocus enabled. During this calibration the table will rise up, depress the autofocus plunger, and then move back to the appropriate focal height.

1. Before completing the autofocus calibration, install the raster table if your engraver is equipped with one.
2. Since the table will rise to depress the autofocus plunger, use the Jog feature to position the lens carriage in a position which will prevent the autofocus plunger and lens cone from coming into contact with the left and or top ruler guides.
3. On the display, press the gear icon to enter the Settings menu:

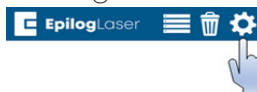

4. Once in the Settings menu, press the Focus button to enter the Focus Commands/Calibrations menu:

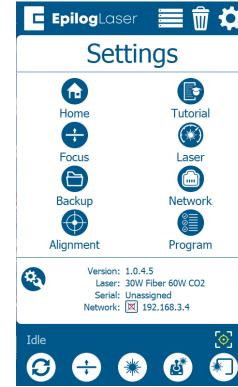

5. Press the AF Plunger button:



6. Press the Start button:



7. Allow the engraver to complete the calibration. Once complete, a success message should appear.

Focus Calibrations for Dual Source Engravers

Focus calibrations must be completed periodically to ensure that the engraver is operating at the correct focal height. Complete this procedure if any of the following behaviors are observed:

- Autofocus is not working.
- Autofocus is moving the table too high or low.
- Laser power appears weak.
- Table movement appears to not coincide with user focus input or crashes.
- Issues with camera calibration.

Additionally, certain component replacements require that the focus calibration procedure to be completed. These components include:

- Z-Axis PCB
- Laser tube
- Control module

Focus calibration must be completed in the order outlined in this procedure.

Table Calibration

The table calibration is a crucial step in the laser focus calibration. During this procedure the table will move from the top to the bottom of the z-axis locating the magnetic sensors along the z-axis PCB. This step must be completed for a successful and accurate focus calibration.

1. Before completing the table calibration install the raster table if your engraver is equipped with one.

2. Since the table will rise to depress the autofocus plunger, use the Jog feature to position the lens carriage in a position which will prevent the autofocus plunger and lens cone from coming into contact with the left and or top ruler guides.
3. On the display, press the gear icon to enter the Settings menu:



4. Once in the Settings menu, press the Focus button to enter the Focus Commands/Calibrations menu:

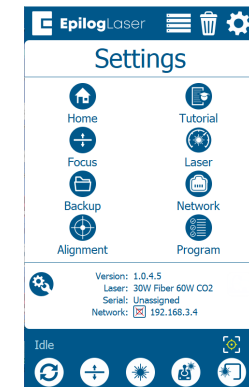

5. Press the Table button:



Focus Calibrations

6. Press the Start button to start the table calibration:

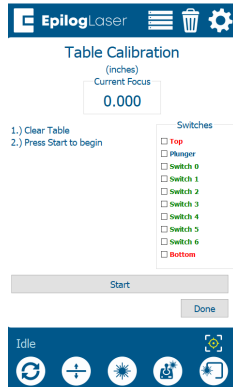

7. Allow the engraver to complete the calibration. Once complete, a success message should appear.

8. Move to the Fiber Focus Procedure.

Fiber Focus Calibration

The fiber focus calibration establishes the focal height of the laser and manual focus gauge. You will run a small job while adjusting the table height to find the correct focal height.

A small piece of anodized aluminum (at least 3" x 3" or 75mm x 75mm) is required to complete this procedure.

1. Open your preferred illustrating program and create a black, raster box measuring ~2" x 2" or 50mm x 50mm.
2. Send the job to the Software Suite.
3. Ensure that the process shows as an engraving job and set the both power and speed at 5-10%.

4. Send the job to the engraver.

5. Once the job is running press the Focus button and slightly raise and lower the table with the joystick while observing the spark coming from the laser hitting the anodized aluminum:



6. While raising and lowering the table, find the height where the spark appears the brightest. If it is difficult to determine, turn off any overhead lights in the room.
7. Once the appropriate table height is found, use the touchpad to lower the power to the lowest power possible while still producing a spark:

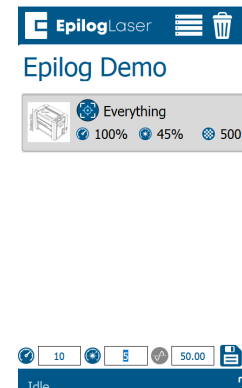

Focus Calibrations

- Continue to raise and lower the table height with the lower power setting to find the height where the spark appears the brightest.

Using the lower power setting allows you to more finely dial in the correct focal height as the spark fades very quickly when the material becomes out of focus.

- Once the correct focal height has been found let go of the joystick and press the Go/Stop button to stop the job. Then press the Reset button to return the laser head back to the home position.
- Remove the anodized aluminum from the engraver.
- On the display, press the gear icon to enter the Settings menu:

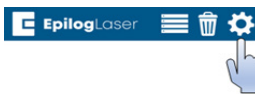

- Once in the Settings menu, press the Focus button to enter the Focus Commands/Calibrations menu:



- Press the Fiber Focus button:



- Ensure that the material thickness used during the previous step is entered in the Thickness box. If using anodized aluminum provided by Epilog Laser, the default value of 0.025" corresponds to the material.
- Press the Start button. This calibration is very fast as the engraver simply notes and saves the current position of the table.
- Press Done.
- Back at the Focus Commands/Calibrations menu, press Fiber Focus:



18. Press the CO2 Focus button:



Since the dual source engraver uses the fiber focus as the default, the engraver will move the table to the calibrated fiber focus height after completing a job.

This step does not calibrate the CO2 focus height but prevents the table from moving during the CO2 focus calibration.

The CO2 Focus Calibration procedure must still be completed.

19. Ensure that the material thickness used during the previous step is entered in the Thickness box. If using anodized aluminum provided by Epilog Laser, the default value of 0.025" corresponds to the material:

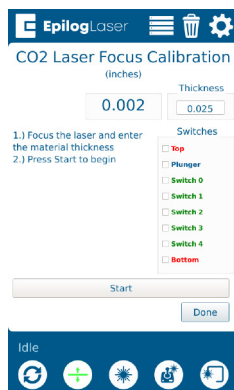

20. Press the Start button.

21. Press Done.

22. Move to the CO2 Focus Calibration procedure.

CO2 Focus Calibration

The CO2 focus calibration establishes the focal height of the laser and manual focus gauge. You will run a small job while adjusting the table height to find the correct focal height.

A small piece of anodized aluminum (at least 3" x 3" or 75mm x 75mm) is required to complete this procedure.

1. Open your preferred illustrating program and create a black, raster box measuring ~2" x 2" or 50mm x 50mm.
2. Send the job to the Software Suite.
3. Ensure that the process shows as an engraving job and set the both power and speed at 5-10%.
4. Send the job to the engraver.

Focus Calibrations

- Once the job is running press the Focus button and slightly raise and lower the table with the joystick while observing the spark coming from the laser hitting the anodized aluminum:

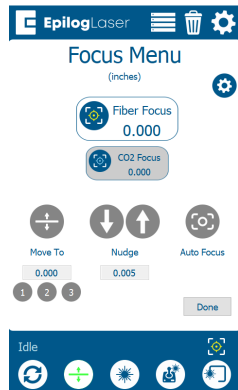

- While raising and lowering the table, find the height where the spark appears the brightest. If it is difficult to determine, turn off any overhead lights in the room.
- Once the appropriate table height is found, use the touchpad to lower the power to 3-5%:

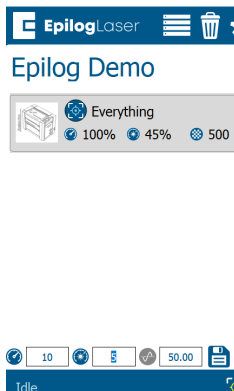

- Continue to raise and lower the table height with the lower power setting to find the height where the spark appears the brightest.

Using the lower power setting allows you to more finely dial in the correct focal height as the spark will fade very quickly when the material becomes out of focus.

- Once the correct focal height has been found let go of the joystick and press the Go/Stop button to stop the job. Then press the Reset button to return the laser head back to the home position.
- Remove the anodized aluminum from the engraver.
- On the display, press the gear icon to enter the Settings menu:



- Once in the Settings menu, press the Focus button to enter the Focus Commands/Calibrations menu:

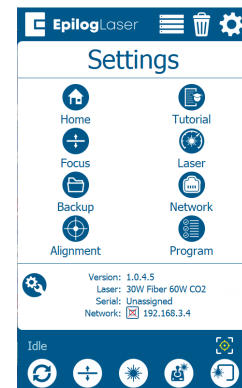

- Press the CO2 Focus button:



Focus Calibrations

14. Ensure that the material thickness used during the previous step is entered in the Thickness box. If using anodized aluminum provided by Epilog Laser, the default value of 0.025" corresponds to the material:

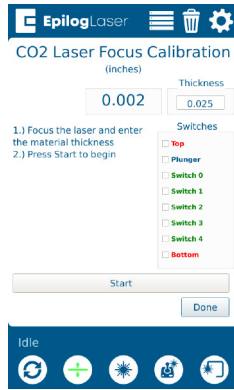

15. Press the Start button. This calibration is very fast as the engraver simply notes and saves the current position of the table.
16. Press Done.
17. Move to the Autofocus Calibration procedure.

Autofocus Calibration

The autofocus calibration takes note of, saves, and uses the CO2 focus calibration value to ensure that the table moves to the correct focal height when running a job with the autofocus enabled. During this calibration the table will rise up, depress the autofocus plunger, and then move back to the appropriate focal height.

1. Before completing the autofocus calibration, install the raster table if your engraver is equipped with one.

2. Since the table will rise to depress the autofocus plunger, use the Jog feature to position the lens carriage in a position which will prevent the autofocus plunger and lens cone from coming into contact with the left and or top ruler guides.

3. On the display, press the gear icon to enter the Settings menu:



4. Once in the Settings menu, press the Focus button to enter the Focus Commands/Calibrations menu:

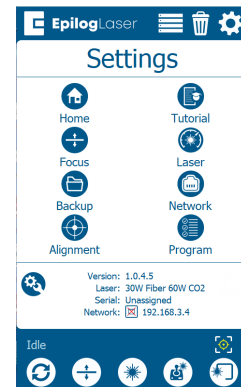

5. Press the AF Plunger button:



Focus Calibrations

6. Press the Start button:

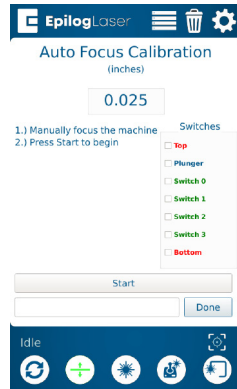

7. Allow the engraver to complete the calibration. Once complete, a success message should appear.

If further assistance is required, contact Epilog Laser Technical Support by phone at 303-215-9171, or by email at tech@epiloglaser.com.